

ISASPORT

Cal 8270 / 2300



SWISS MADE



FAR EAST ASSEMBLY

11 1/2'''
25.60 mm
H. 4.60

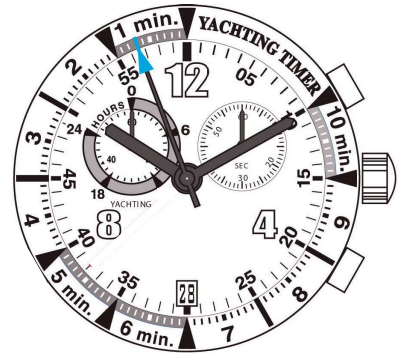

In conformity with RoHS standard

SPORTS



Yachting



60 Sec. Timer



60 Sec. Chrono



96 Hrs. Chrono



Small Sec.



End Of Life



Date by Window
(Big Date available)

ISASWISS

WATCH MECHANISMS

ISASPORT

8270 / 2300**SWISS MADE****FAR EAST ASSEMBLY****11 1/2'''****25.60 mm****Caractéristiques :**

Mouvement régata analogique / électronique à quartz. Moteurs rotatifs pas à pas. Petite seconde, 1 pas par seconde. Quantième par guichet, correcteur de quantième rapide.

Fin de vie de pile (EOL) : déplacement de l'aiguille de petite seconde de 4 pas toutes les 4 secondes.

Compte à rebours / compteur de minutes à l'aide de la trotteuse centrale. Compteur d'heures et de secondes.

Chronométrage : *Avant le départ* : compte à rebours réglable de 10 minutes à 1 minute, avec signaux sonores.

La course commence : (fin du décomptage) passage automatique en mode chronométrage. Durée maximum 96h.

Dispositif stop mécanique et électronique.

9 rubis.

Characteristics :

Yachting analogical / electronic movement. Rotating stepping motors. Small second, 1 step per second.

Date by window, quick date correction.

End of life (EOL): indication by small second hand jumping 4 successive steps every 4 seconds.

Minute count down and counter with the central hand. Seconds and hours counter.

Timing function : *Before sailing*: Adjustable count down start time from 10 minutes to 1 minute, with alarm signals.

When the race starts (end of count down): automatic activation of race timing mode. Maximum duration 96h.

Stop device and current breaker.

9 jewels.

Kennzeichnungen :

Analog Regatta elektronisches Quarzwerk. Schrittschaltmotoren. Kleine Sekunde, 1 Schritt pro Sekunde.

Rasche Korrektur des Datums mittels Stellwelle.

Batterie Spannung Überwachung : Kleine Sekunde Zeiger springt 4 Schritte jede 4 Sekunden.

Rückwärts Zähler/Zähler mit Zentrum Zeiger. Stunden und Sekunden Zähler.

Zeitmessung: *Vor Regatta Anfang* - Rückwärts Zähler mit Regelsystem vom 10 to 1 Minute mit akustischen Signalen

Regatta Beginn - (Ende den Abzahl). Zeitmessung mode start automatisch. Maximal 96 Stunden.

Möglichkeit mechanisch oder elektrisch zu stoppen

9 Steine.

Critères Criteria Kriterium	Conditions Conditions Bedingungen	Min.	Typ.	Max.	Unités Units Einheit
Consommation Current consumption Stromaufnahme	U=1.55V T=25°C		1.95		µA
Marche instantanée Instantaneous rate Momentaner Gang	U=1.55V T=25°C	- 0.5 (-15)		+ 0.5 (+15)	s/jour s/day s/Tag (s/mois s/month s/Monat)
Température de fonctionnement Operating temperature Betriebstemperatur		0		+ 50	°C
Résistance aux champs magnétiques Resistance to magnetic fields Magnetfeldabschirmung			1500 (18.8)		A/m (Oe)

Qté Qty Menge	Désignation Designation Bezeichnung	Type Model Typ	Tension Voltage Spannung	Code Code Code	Capacité Capacity Kapazität	Autonomie théorique Theoretical Autonomy Theoretische Gangreserve
1	Pile Battery Batterie 9.50 x 2.70	SR 927 W High drain	1.55 V	399	55 mAh	Mois 39 Months 32* Monate

* Avec 1h. fonction régata- * With 1h. yachting function - *Mit 1S. Regatta Funktion

ISASWISS

WATCH MECHANISMS

www.isaswiss.com

ISA SWISS S.A.
Champ-Nauger 2
CH -2416 Les Brenets
Switzerland
Tél +41 (0)32 930 80 85
Fax +41 (0)32 930 80 86

ISA PACIFIC Co. Ltd.
Room 1605, Eastern Center
1065 King's Road, Quarry Bay,
Hong-Kong
Tél +852 21 68 33 88
Fax +852 25 18 30 33

Redémarrage :

Après la pose de la pile, ou si le mouvement réagit anormalement après la pose de la pile, une réinitialisation peut être réalisée en court-circuitant la capacité indiquée à l'aide de brucelles métalliques.

Cette opération est plus sûre que la dépose et la repose de la pile et garantit un redémarrage normal du mouvement.

Après cette opération, le mouvement est dans la même configuration qu'après un changement de pile et la procédure d'initialisation doit être effectuée comme décrite sur le mode d'emploi.

Restarting :

After battery insertion, or if movement does not work correctly after battery setting, a reboot can be carried out by short-circuiting the indicated capacitor with metallic tweezers.

This operation is far better than removing and reinserting the battery and thus ensures a correct restart of the movement.

After that, the movement is in the same configuration as after a battery change and an initialization procedure has to be carried out as described in user manual.

Neu starten :

Nach der Einfügung der Batterie, oder wenn das Uhrwerk ungewöhnlich nach der Verlegung der Batterie reagiert, kann, durch Kurzschluss der angegebene Kapazität mittels Metallpinzette, ein Neubeginn verwirklicht werden.

Diese Operation ist sicherer als das Herausnehmen und Wiedereinsetzen der Batterie und garantiert einen normalen Wiederanlauf des Uhrwerkes.

Nach dieser Operation ist das Uhrwerk in derselben Konfiguration wie nach Einfügung einer neuen Batterie und das Initialisierungsverfahren muss nach der Gebrauchsanweisung durchgeführt werden.

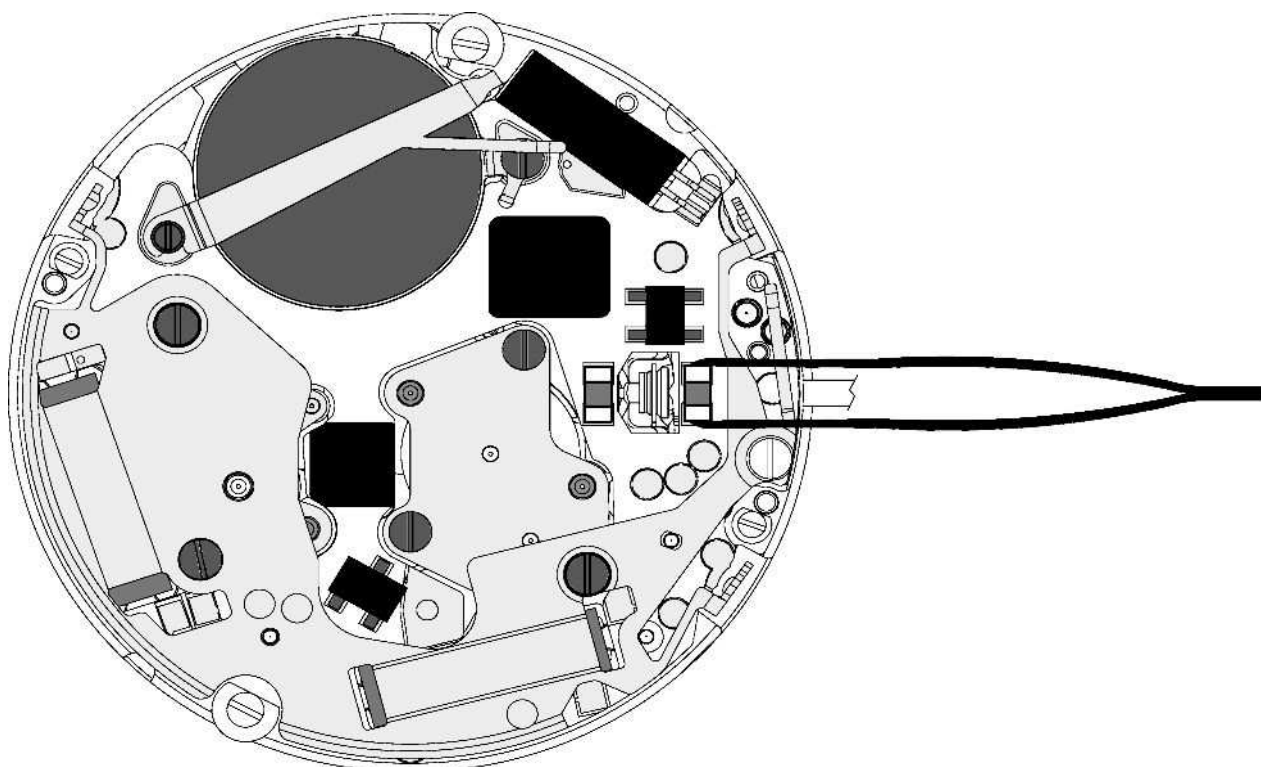

CAGE / FRAME

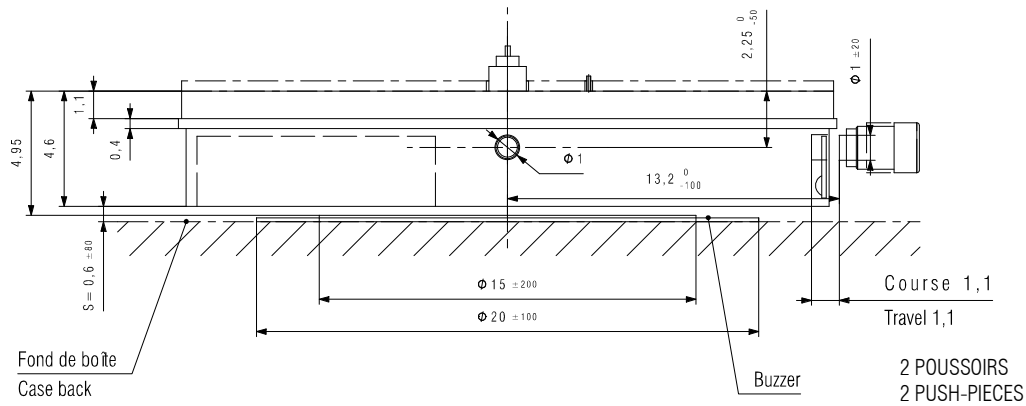

COUPE / CUT F-F

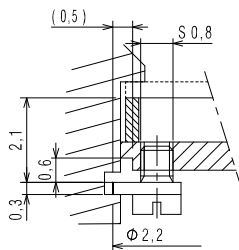

FIXATION DU MOUVEMENT
FASTENING OF MOVEMENT
- CLEFS DE FIXE OU CERCLE D'EMBOITAGE
CASE SCREWS OR CASING RING
- AUTRE FIXATIONS POSSIBLE
OTHER FASTENINGS POSSIBLE

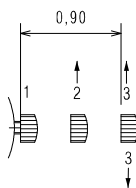

- 1: REPOS - REST
- 2: POSITION POUR INITIALISATION DES AIGUILLES DE COMPTEURS
STEM POSITION FOR THE CALIBRATION OF COUNTER HANDS
QUANTIEME - DATE
- 3: MISE A L'HEURE
HANDS SETTING
STOP

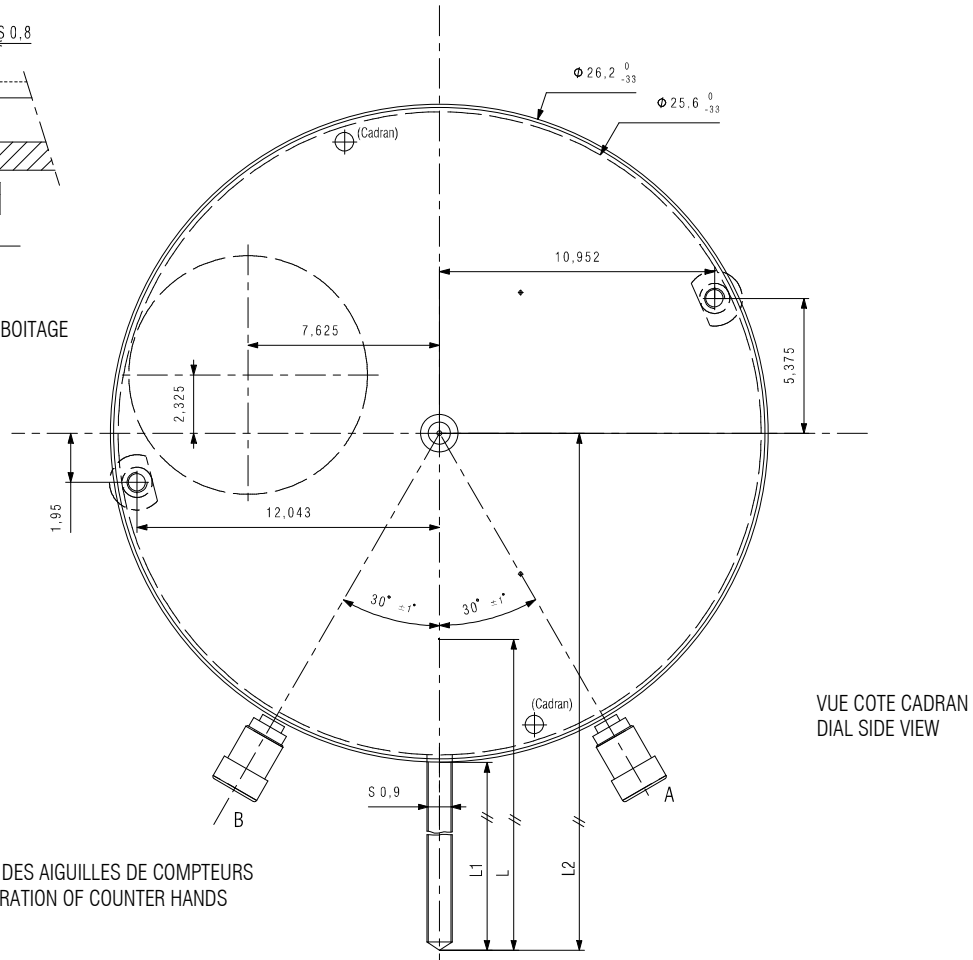

Tige en position repos / Stem in rest position	L	L1	L2
Standard / Standard	18.05 +/-100	9.40	22.5
Longue / Long	25.00 +/-100	16.35	29.45

DIMENSIONS IN mm. - TOLERANCES IN μ m.

CADRAN / DIAL

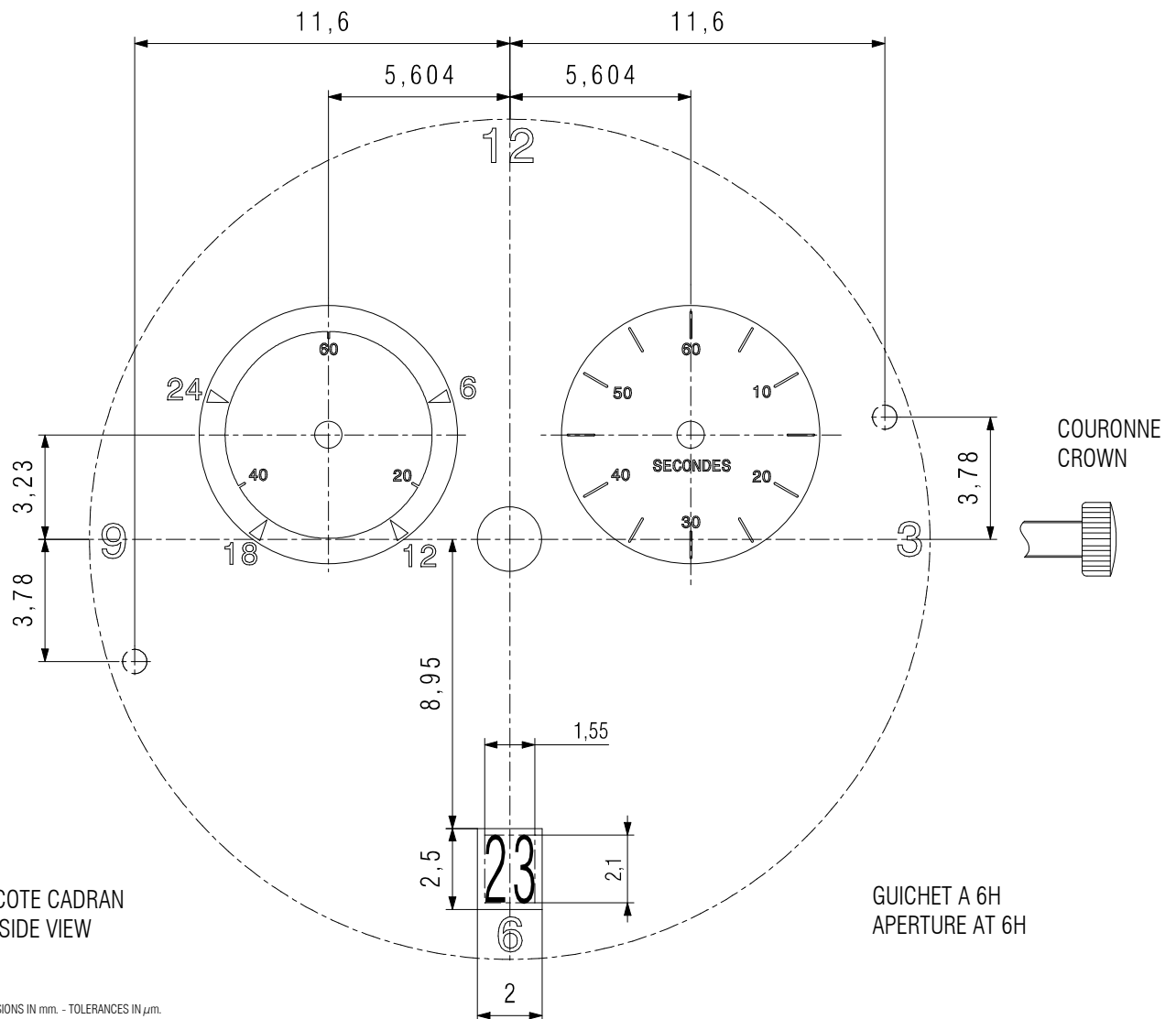
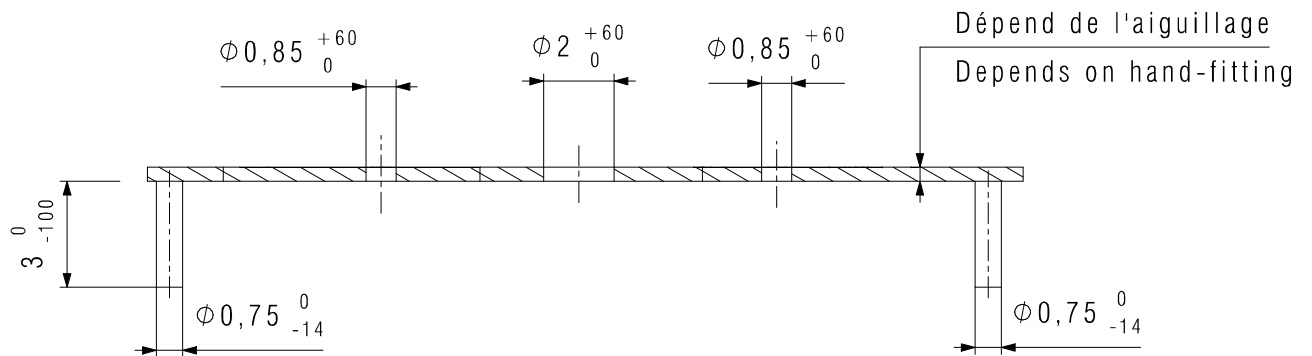

VUE COTE CADRAN
DIAL SIDE VIEW

DIMENSIONS IN mm. - TOLERANCES IN μ m.

In conformity with RoHS standard

Doc. n° 0312230 - A Up date . 26/03/2014 - Page 5

CADRAN / DIAL

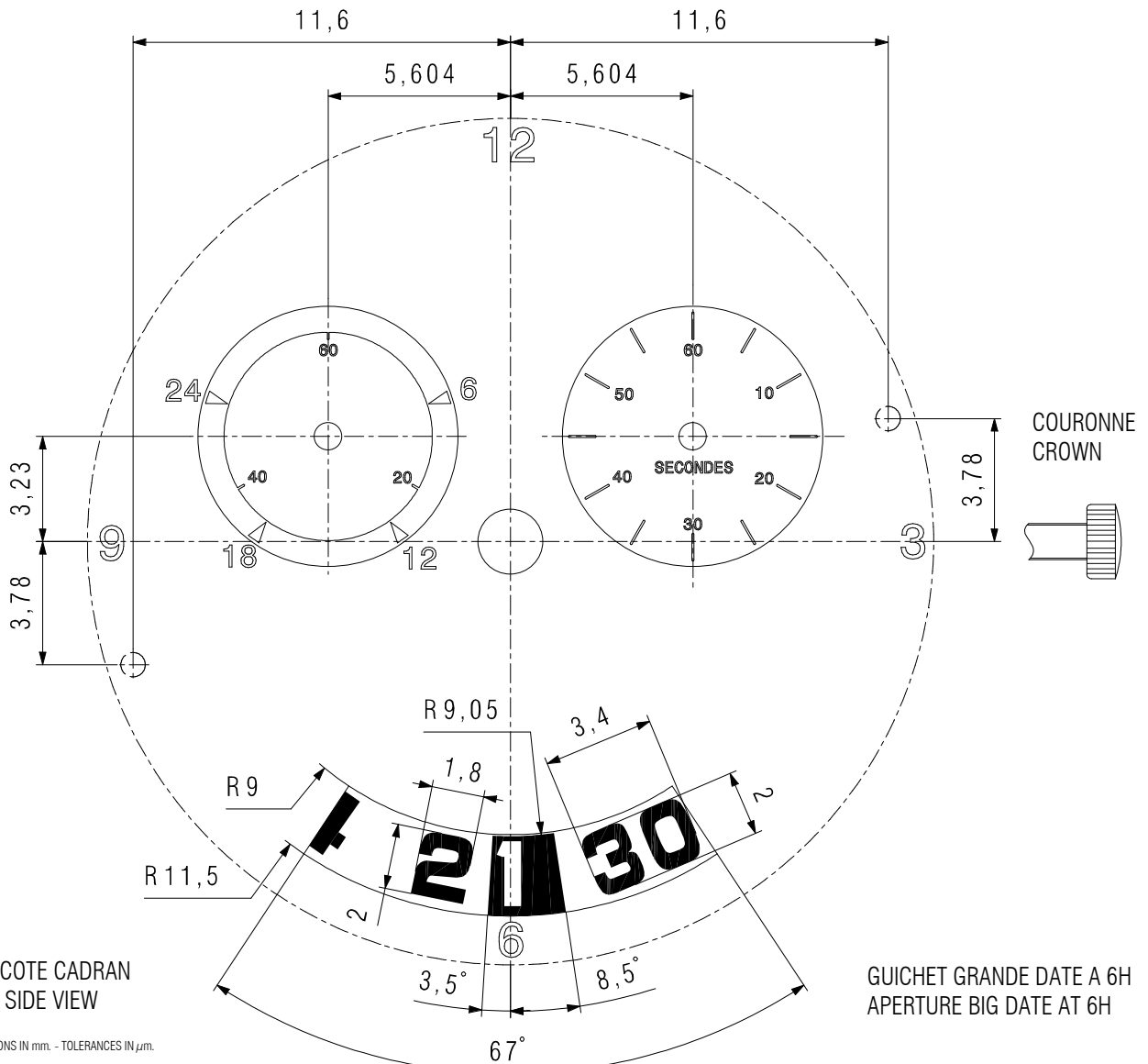
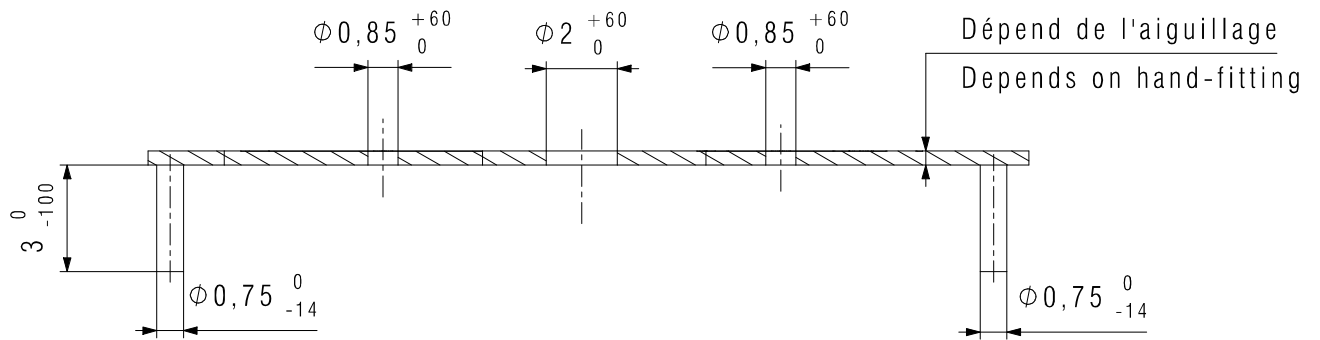

In conformity with RoHS standard

Doc. n° 0312230 - A Up date . 26/03/2014 - Page 6

CADRAN / DIAL

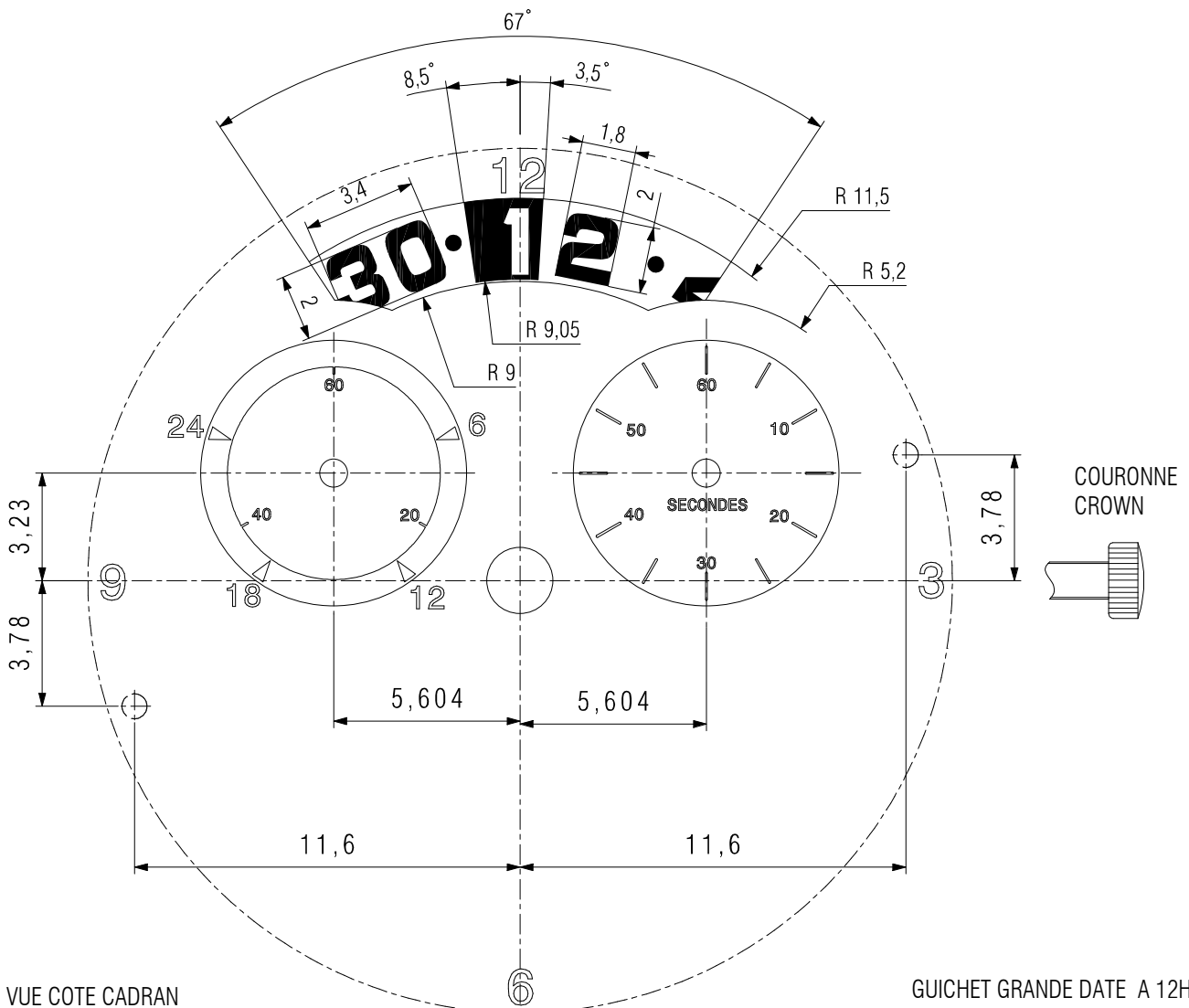
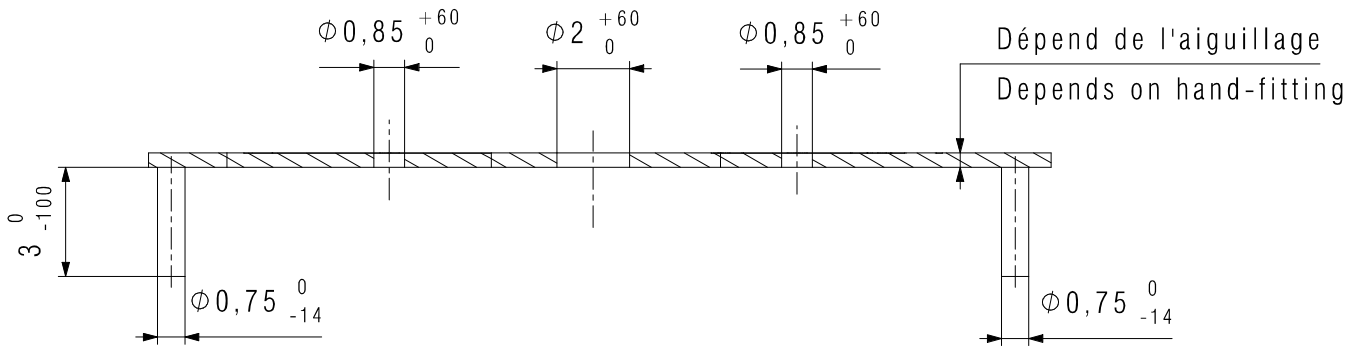

VUE COTE CADRAN
DIAL SIDE VIEW

GUICHET GRANDE DATE A 12H
APERTURE BIG DATE AT 12H

DIMENSIONS IN mm. - TOLERANCES IN μ m.

In conformity with RoHS standard

Doc. n° 0312230 - A Up date . 26/03/2014 - Page 7

AIGUILLAGE / HAND-FITTING

AUTRES AIGUILLAGES SUR DEMANDE
OTHER HAND-FITTING ON REQUEST

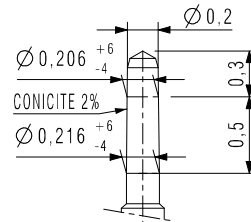
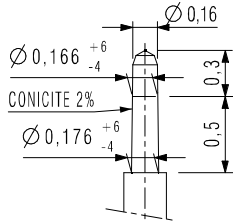

PETITS COMPTEURS
SMALL COUNTERS

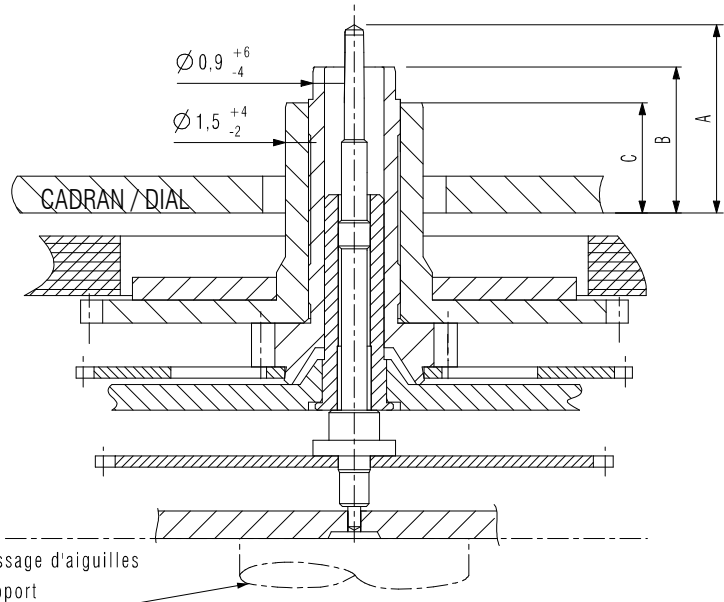
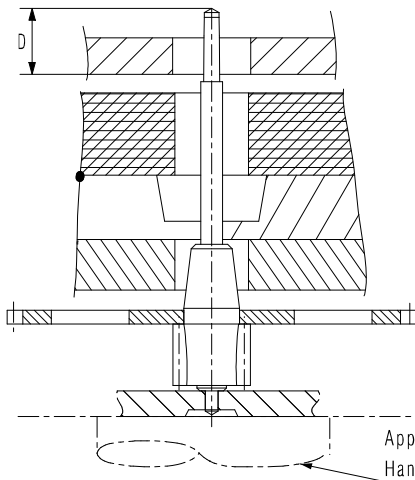

AIGUILLAGE / HAND-FITTING	Dépassement / Height over dial seat				Epaisseur cadran / Dial Thickness
	A	B	C	D	
N°2	2.05	1.60	1.20	0.70	0.40
N°4 special	2.50	2.05	1.65	0.70	0.40
HAUTEUR TUBE / TUBE HEIGHT	0.70	0.35	0.60	0.70	--

CHOCS 450 g / 450 g SHOCKS	Balourd / Unbalance	FORCE DE CHASSAGE / PRESS-IN-FORCE
Aiguille des heures - Hour Hand	—	≤ 25 N
Aiguille des minutes - Minute Hand	≤ 10 μNm	≤ 25 N
Trotteuse centrale - Central Hand	≤ 0.8 μNm	≤ 25 N
Aiguilles des petits compteurs - Small counters - Hands	≤ 0.2 μNm	≤ 20 N

DIMENSIONS IN mm. - TOLERANCES IN μm.

In conformity with RoHS standard

Doc. n° 0312230 - A Up date . 26/03/2014 - Page 8

ISASPORT

8270 / 2300



SWISS MADE



FAR EAST ASSEMBLY

11 1/2'''

25.60 mm

EXEMPLE DE PRESENTATION
DESIGN SAMPLE



In conformity with RoHS standard

Doc. n° 0312230 - A Up date . 26/03/2014 - Page 9

ISASWISS
WATCH MECHANISMS

www.isaswiss.com

ISA SWISS S.A.
Champ-Nauger 2
CH -2416 Les Brenets
Switzerland
Tél +41 (0)32 930 80 85
Fax +41 (0)32 930 80 86

ISA PACIFIC Co. Ltd.
Room 1605, Eastern Center
1065 King's Road, Quarry Bay,
Hong-Kong
Tél +852 21 68 33 88
Fax +852 25 18 30 33

DIRECTIVES POUR LA REALISATION DU FOND DE BOITE CASE BACK MANUFACTURING INSTRUCTIONS

Ø 22 SERT A CENTRER LE BUZZER VISUELLEMENT AU COLLAGE
TO POSITION VISUALLY THE BUZZER WHEN GLUING

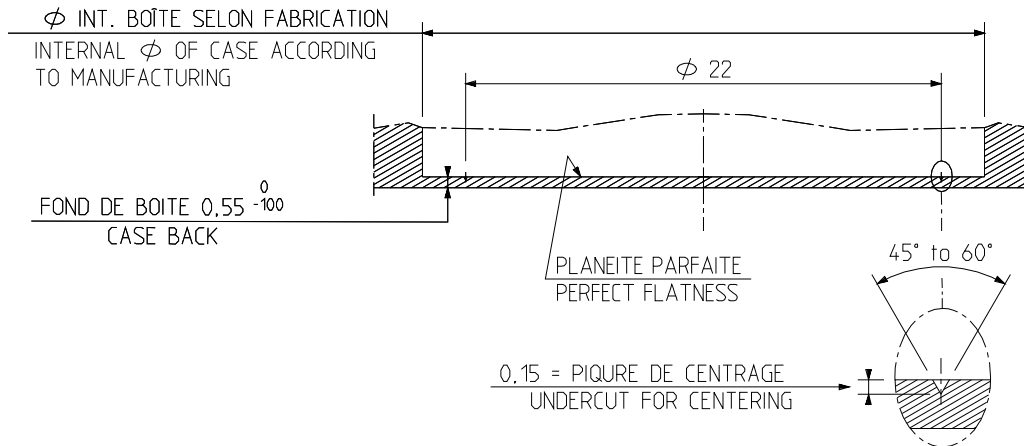

INSTRUCTIONS POUR LE COLLAGE DU BUZZER BUZZER GLUING INSTRUCTIONS

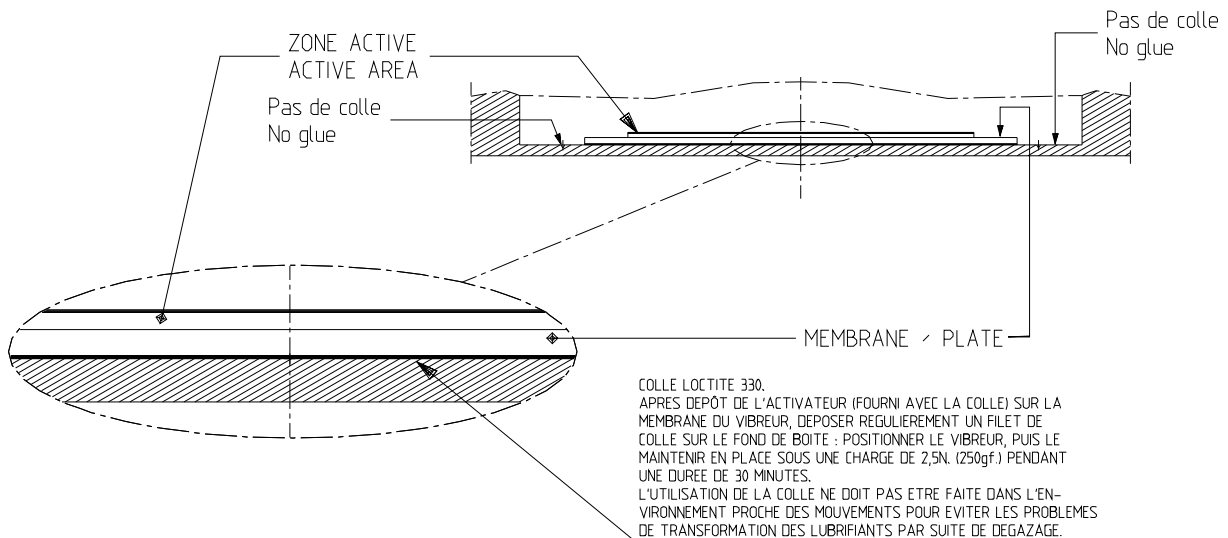

LOCTITE 330 GLUE
AFTER THE DEPOSIT OF THE ACTIVATOR (GIVEN WITH THE GLUE) ON THE PLATE OF THE BUZZER, DEPOSIT REGULARLY A GLUE FILET ON THE CASE BACK : SET THE BUZZER IN THE RIGHT POSITION AND MAINTAIN IT IMMEDIATELY UNDER A PRESSURE OF 2,5N. (250gf.) AT LEAST 30 MINUTES.
REMARKS : THE GLUING OPERATION SHOULD NOT BE DONE CLOSE TO THE MOVEMENTS TO AVOID THE IMPORTANT RISK OF LUBRICANT TRANSFORMATION DUE TO THE GLUE OUTGASING.

DIMENSIONS IN mm. - TOLERANCES IN µm.